

# Utilization of Soil Moisture Sensor as an Early Warning of Drought in Plants with Arduino Microcontroller

Elvira Seftiani Syahfitri

e-mail: [elviraseftiani17@gmail.com](mailto:elviraseftiani17@gmail.com)

Solly Aryza Lubis

e-mail: [sollyaryzalubis@pancabudi.ac.id](mailto:sollyaryzalubis@pancabudi.ac.id)

Rahmaniar

e-mail: [rahmaniar@dosen.pancabudi.ac.id](mailto:rahmaniar@dosen.pancabudi.ac.id)

**Universitas Pembangunan Panca Budi, Indonesia**

## **Abstract**

Drought in plants is one of the common problems that often occurs, especially in potted plants that are indoors and completely dependent on manual watering by the owner. This research aims to design and implement a soil drought early warning system using a soil moisture sensor (FC-28) integrated with an Arduino UNO microcontroller. The system is designed to read the soil moisture level in real-time and provide visual notification through a 5 mm LED indicator. The method used includes designing an electronic circuit consisting of a moisture sensor, Arduino, LED, and other supporting components. The FC-28 sensor detects soil moisture and sends an analog signal to the Arduino for processing. If the moisture value is lower than a predetermined threshold, the Arduino will activate the LED as a sign that the soil is dry. Tests were conducted on three types of planting media (loose soil, clay, and husk mixture) in three different moisture conditions (wet, humid, and dry). The test results show that the system can detect drought conditions with consistent accuracy across different types of growing media. The system is effective as a simple monitoring solution that is easy to apply for household-scale plant monitoring. In addition, the system has the potential to be further developed towards watering automation and integration with the Internet of Things (IoT).

**Keywords:** Soil Moisture Sensor, Arduino, Plant, Drought, Moisture Detection, LED.

International Conference on Digital Sciences and Engineering Technology (ICDSET)  
Theme: "Integration and Interdisciplinarity: Digital Sciences, Engineering and Technology  
Concepts Frameworks"

Volume 2, No 1 (2025)

<https://proceeding.pancabudi.ac.id/index.php/ICDSET/>

## Introduction

Drought in plants is one of the serious problems that often occurs in plant cultivation activities, both in the agricultural sector and in households such as ornamental plants. Lack of water can disrupt the process of photosynthesis, metabolism, and overall plant growth (Putri & Santosa, 2021). This especially affects plants grown in pots, as they do not receive a natural supply of water from the environment such as rainfall, but instead depend entirely on human watering. In the modern era, human activities are increasingly hectic, especially for those who have full-time jobs. Time constraints and high busyness make some people often forget to do routine watering. As a result, plants become dry, wilt, and potentially die due to lack of attention to their water needs (Wahyuni & Hidayat, 2022). This problem shows the importance of a monitoring system that can provide early warning of soil moisture conditions so that watering actions can be taken on time.

Along with the development of technology, the utilization of electronic sensors in agricultural or ornamental plant monitoring systems has begun to grow. One sensor that is widely used to detect water content in soil is the soil moisture sensor. This sensor works by detecting the level of soil conductivity that changes with the water content contained in it (Saputra & Nurhadi, 2020). By integrating this sensor into a microcontroller-based system such as Arduino, users can easily know when plants need watering without having to manually check soil conditions.

Based on this background, the author designed a simple system called Mini Soil Moisture Sensor (MSMS), which aims to monitor soil moisture in real-time and provide early warning through a 5 mm LED indicator. When the soil moisture drops below a predetermined threshold, the LED will light up as a visual signal that the plants require watering. This device is suitable for potted plants, both indoors and outdoors.

The design of this tool is economical, easy to make, and can be used as a practical solution for urban communities who want to keep their plants healthy without having to spend time and energy on manual checking every day. In addition, the use of this technology is also in line with the principle of smart agriculture, which is increasingly popular in facing the challenges of efficiency and sustainability in modern agriculture (Kusuma et al., 2021).

It is hoped that through this research, the community can utilize simple technology to increase the effectiveness of plant care and reduce the risk of drought damage. This research also contributes to the application of microcontroller-based monitoring systems to support innovation in small-scale agriculture and horticulture.

## Literature Review

### A. Soil Moisture Sensor FC-28

A soil moisture sensor is an electronic component that functions to detect the moisture content in the soil. One commonly used type is the FC-28, which works by measuring the resistance between two electrodes that are stuck into the ground. The more water content in the soil, the resistance between the two electrodes will decrease, and vice versa (Sari et al., 2021). The FC-28 sensor has two output modes, analog and digital. The analog mode provides a voltage signal proportional to the moisture content, while the digital mode generates an ON/OFF signal based on a certain threshold determined through a potentiometer on the sensor board. The main advantages of FC-28 are its low price, ease of integration with microcontrollers such as Arduino, and low power consumption, making it suitable for small-scale applications such as potted plant monitoring systems (Prasetyo et al., 2020).

## B. Arduino UNO microcontroller

Arduino UNO is an ATmega328P-based microcontroller board that is widely used in the development of simple electronic systems. Arduino provides a programming environment that is easily understood by beginners and supports the integration of various types of sensors, including soil moisture sensors. In the context of this research, Arduino acts as a data processor from the humidity sensor and an output controller (LED indicator) based on the measurement results (Kusuma et al., 2021).

The use of Arduino in plant monitoring systems has been widely developed, ranging from watering automation systems to internet-based notifications. However, this research focuses on the basic function of early warning using LED output as a form of visual monitoring system that is power efficient and easy to apply.

## C. 5 mm LED as a Drought Indicator

LED (Light Emitting Diode) is an optoelectronic component that produces light when electrified. A 5 mm LED was chosen in this study due to its small size, low power consumption, and economical price. In the context of the Mini Soil Moisture Sensor (MSMS) tool, the LED serves as an indicator that the soil is dry. When the sensor detects that the soil moisture drops below a certain threshold, the LED will light up as a visual warning to the plant owner (Wahyuni et al., 2022). The LED output was chosen due to its direct nature and does not require decoding of information, making it very suitable for lay users. Although simple, this method has proven to be effective in increasing attention to plant conditions, especially for busy individuals who often forget to water plants regularly.

## Research Methods

This research develops a drought early warning tool for plants based on soil moisture sensors, with a simple design approach without using a microcontroller. The main focus is to build a system that is economical, practical, and easy to use by anyone, especially for plant owners who have limited time.

### A. Mini Soil Moisture Sensor System Design

The design process begins with identifying the functional requirements of the device, namely the ability to detect dry soil conditions and provide visual warnings directly. Therefore, the system was designed in a compact manner using only the FC-28 sensor and LED as output, without the involvement of Arduino or other digital control devices. With this approach, the device can function as an instant solution to detect the dryness of potted plants in the home environment.

### B. Components and their Functions

Some of the important components used in the construction of the tool include:

- a. FC-28 Soil Moisture Sensor: This sensor is used to read the moisture content of the soil. When the soil is dry, the sensor will produce a low logic output that can be directly used to turn on the indicator.
- b. 5 mm LED: As the main indicator in this tool. When the sensor detects dryness, the LED lights up to alert the user.
- c. Jumper Cables (Wires): Serves as a conductor of electrical signals between components, connecting sensors, LEDs, and power sources.
- d. 9V Battery: Used as an energy source for the entire system. The voltage of the battery is adjusted to match the operational requirements of the sensors and LEDs.

- e. PCB board: It is the medium of integration of all components. The use of PCBs makes the tool more neat, sturdy, and can be used portably.

### **C. Tool Working Principle**

It works automatically based on the readings from the FC-28 sensor. The sensor is placed into the growing medium in a pot. When the soil water content drops below a certain threshold (dry soil), the sensor activates an output line connected directly to an LED. The LED then lights up to provide a visual signal to the user that the plant needs water. Conversely, if the soil is still moist or wet, the LED remains off, indicating that no watering action is required.

### **D. Signal Communication Mechanism**

Although this system does not use a microcontroller, the communication mechanism between components still takes place through a simple circuit. The humidity data is read directly by the FC-28 sensor, then processed internally by the comparator module on the sensor. The value generated by the sensor then directly regulates the LED's on state, without going through the programming logic process. This communication model allows for quick and efficient reactions without the need for further data processing, making the device highly energy-efficient and responsive to changing soil conditions.

### **E. Testing Process**

To test the reliability of the device, functional testing was conducted under two main conditions:

- a. Dry Soil: The sensor was plugged into soil that had been left to dry for 24 hours. As a result, the LED automatically lit up, indicating that the system was able to detect the lack of water.
- b. Wet Ground: The sensor is plugged into soil that is watered until it is moist. In this condition, the LED remains extinguished, indicating that the sensor is able to recognize that the soil does not require watering.

Test results show that the device can provide quick and accurate notifications of changes in soil moisture, making it effective as an early warning system.

## **Results and Discussion**

### **A. System Block Diagram**

The design of the Mini Soil Moisture Sensor system is done with a simple approach that aims to simplify the process of soil moisture detection in pots. The system is designed to be used by users without requiring complex technical understanding. The device works by detecting the moisture content in the soil using the FC-28 sensor, then providing a visual signal to the user through an LED indicator. This process is described systematically in the following block diagram:

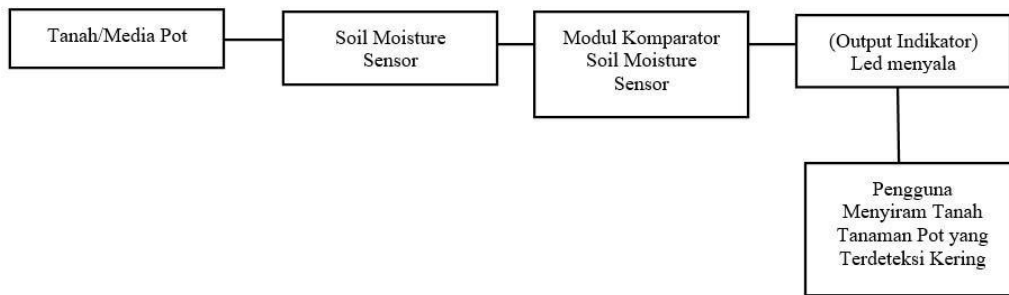

**Figure 1.** Diagram of Soil Moisture Sensor

The following is a description and explanation of each block contained in the diagram:

a. Potting Soil/Media

The soil or growing medium in a pot is the main object that is the focus of measurement. In the context of this system, the soil not only acts as a growing medium for plants, but also as a medium where the sensor detects moisture content. The FC-28 sensor will be plugged into the soil and make direct contact to determine the moisture level. Soil that is too dry will change the electrical conductivity read by the sensor. Therefore, the physical condition of the soil plays an important role in the success of moisture detection.

b. Soil Moisture Sensor FC-28

The FC-28 soil moisture sensor is the main component in this system. It works on the principle of measuring the resistance between two metal electrodes inserted into the soil. If the soil has a high water content, the resistance will be low and the conductivity will increase. Conversely, in dry soil conditions, the resistance will increase and the electric current flowing will decrease. This value then becomes the initial data (input) to be forwarded to the next module. This sensor is the backbone of the system because it functions as an early detector of soil conditions in real-time (Sari et al., 2021).

c. Comparator Module

After the sensor reads the humidity level, the resulting analog signal will be processed by the comparator module. This module compares the signal value from the sensor with a predetermined threshold using a potentiometer. If the signal from the sensor indicates that the soil is drier than the threshold, then the module will activate the digital output as a sign that the humidity is already below normal. The comparator module is responsible for converting the analog signal into a logic high (HIGH) or logic low (LOW) digital signal, which is then forwarded to the LED indicator.

d. Indicator Output (5 mm LED)

LED (Light Emitting Diode) serves as an indicator output from the system. In the design of this tool, a 5 mm LED is used which lights up when the soil is dry. If the LED is on, then it means the user needs to do watering. The LED does not light up if the soil moisture is still within normal limits. The function of the LED in this system is very important because it is the direct interface between the tool and the user. Its visual, fast and power-efficient nature makes it a great choice for a simple monitoring

tool. In addition, the LEDs can be seen from a distance, making it easier for users to know the status of the plants without having to get close or check manually.

e. User

The user is the last element in the system flow. In this case, the user is an individual who takes care of plants and needs quick and accurate information about soil moisture conditions. The user does not need to understand the technical details of the device, simply by observing the LED indicators that are on or off. This shows that the Mini Soil Moisture Sensor system is designed with a user-friendly concept, so that it can be used by anyone, including people who do not have a background in technology or agriculture. The information provided by the system allows users to take timely action in watering plants and maintaining the moisture balance of the growing medium.

**B. System Analysis**

Analysis of this system shows that each component is integrated into a simple yet effective communication flow. The advantages of this system include:

- a. **Simplicity:** The system works without a microcontroller, resulting in low manufacturing costs and easy assembly. **Real-time Monitoring:** Information is provided immediately without delay.
- b. **Energy Efficiency:** Components such as LEDs and sensors have low power consumption.
- c. **Ease of Use:** Users can simply look at the LED indicator to know the soil condition. **Portability:** It can be used in different types of pots and is easy to move.

However, this system has limitations, such as: No data recording or logging of soil conditions. It cannot be controlled remotely because it does not use an IoT-based system. The threshold must be adjusted manually via the potentiometer on the comparator module. Despite its limitations, this tool is still very useful in the context of household and educational use.

**Flow Chart**

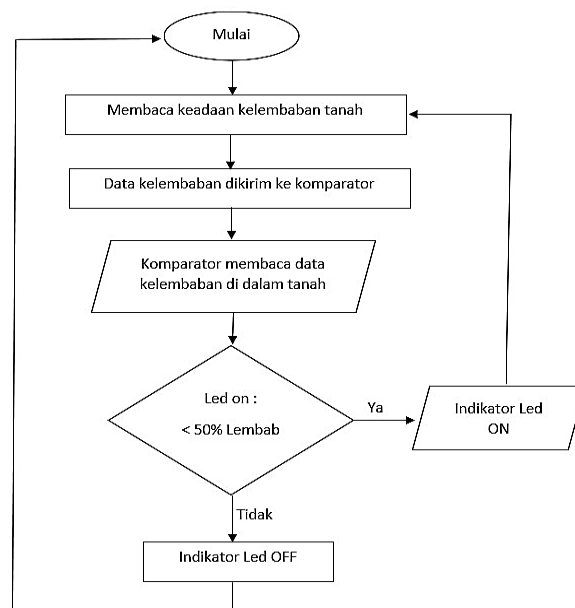

**Figure 2.** Flowchart of soil moisture sensor

### **A. System Flowchart**

As seen in Figure 3, the Mini Soil Moisture Sensor system is designed with a simple yet effective workflow. The flowchart illustrates the system's repetitive and automated work process, starting from the moment the device is activated and the sensor is embedded into the soil. The sensor will continuously read the soil moisture level as the initial data of the whole process. The data obtained from the sensor is then sent to the built-in comparator module integrated in the FC-28 sensor. This module functions to compare the actual moisture value with a predetermined threshold. If the reading shows that the soil moisture is lower than the threshold (meaning the soil is dry), the sensor will activate the LED as a visual indicator. Conversely, if the soil is still moist, then the LED does not light up and the system returns to reading the soil condition from the beginning.

### **B. Tool Work Logic**

The design of the Mini Soil Moisture Sensor is built in a vertical position, with the FC-28 moisture sensor located at the bottom. This position allows the sensor to be plugged directly into the growing medium for maximum direct contact with the soil. Meanwhile, an indicator LED is placed at the top of the device to be easily visible to the user as a visual cue when the soil starts to dry out. When the device is used, the FC-28 sensor starts measuring the soil moisture content. The result of this measurement is an analog voltage that is sent to the comparator module located on the sensor. The comparator module then works by comparing the voltage from the sensor with the set threshold voltage. If the voltage is lower than the threshold, the soil condition is considered dry and the comparator will send a signal to the LED to light up. If the voltage from the sensor is higher than the threshold, then the soil is still moist and the LED remains off. The system is designed to run automatically and continuously, so the sensor will re-read the soil moisture, ensuring that users are always up to date with the condition of their growing medium.

### **C. Hardware Design**

The hardware of the Mini Soil Moisture Sensor is designed to be simple, cost-effective, yet functional. The main components used include FC-28 sensor, 5 mm LED, jumper cable, 9volt battery, and PCB board as installation media. All these components are organized into a compact system that can be installed directly into the plant pot without requiring much space. The FC-28 sensor is placed at the bottom to be inserted into the soil, while the LED is mounted at the top as a visual indicator. Wires are used to connect the power source (battery) with the sensor and LED through the PCB board. The PCB board serves as the main foundation that holds all components together, as well as ensuring stable and regular connectivity. The physical design of the device also considers ease of use for home users, so that the device can be used without the need for technical expertise.



a. Soil Moisture Sensor FC-28 b. 5 mm Led c. 220 Ohms Resistor d. wires e. 9volt battery f. Project Board



g. arduino

**Figure 3. Tool Kit**

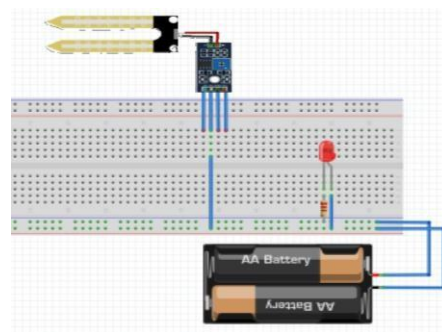

**Figure 4. Soil moisture sensor design**

#### D. System Advantages

- a. Effectiveness of Drought Detection. The Mini Soil Moisture Sensor (MSMS) system has the advantage of effective detection of soil drought conditions. The FC-28 sensor is able to read soil moisture levels directly and accurately. When the soil is dry, the 5 mm LED will light up as a visual warning indicator. Conversely, if the soil is still moist, the LED will not light up. This allows the device to provide quick and simple information to the user for immediate watering.
- b. Simple Design and Low Cost. This tool is designed with a minimalist and cost-effective concept. The MSMS does not require a microcontroller or digital programming, but is still able to perform the moisture detection function effectively. The use of easily available components and low production costs make this tool very suitable for household and educational use, without burdening the budget.

- c. Easy Installation. The MSMS is slim and lightweight, making it easy to install in various types of plant pots. The installation process is quite simple-users only need to stick the sensor into the soil and ensure that the battery and connections between components are properly installed. The LED positioned at the top of the device also makes it easily visible, allowing users to monitor soil conditions without difficulty.

## Results

The Mini Soil Moisture Sensor (MSMS) was tested using three types of commonly used growing media: loose soil, clay, and a mixture of husks. Each planting medium was tested in three different moisture conditions: wet, moist, and dry. The success indicator of the device is seen from the status of the 5 mm LED which lights up when the soil is dry, and turns off when the moisture is still sufficient.

**Table 1.** Mini Soil Moisture Sensor (MSMS) Testing Results

Planting Media	Humidity Conditions	5 mm LED output
Loose Soil	Wet	Die
	Moist	Die
	Dry	Light up
Clay	Wet	Die
	Moist	Die
	Dry	Light up
Husk Mix	Wet	Die
	Moist	Die
	Dry	Light up

Based on the results shown in Table 1, the Mini Soil Moisture Sensor showed consistent performance and good accuracy in detecting the level of dryness in various types of growing media. In all soil types tested (loose soil, clay, and husk mixture), the 5 mm LED only lights up when the soil is completely dry, and remains off in both wet and moist conditions. This shows that the FC-28 sensor used in the MSMS system can effectively identify changes in soil moisture regardless of the texture or composition of the growing medium. The sensor does not give false positive signals in moist or wet soil, indicating that the voltage threshold on the comparator module is well adjusted.

The consistency of the results also shows that the effect of soil type on sensor performance is not significant in the context of dry condition detection. This is a plus point of the MSMS tool as users can apply it to different types of pots or growing media, without the need to recalibrate the sensor for each type of soil. However, since the indicator only lights up in "dry" conditions, the user still does not get more detailed information about the moisture level when the soil is in "moderately moist" conditions. This again shows that the MSMS system is suitable for basic detection, not for numeric or graph-based monitoring. Overall, the test results prove that the MSMS tool has worked well in accordance with its design objective, which is to provide visual early warning when plants are in drought conditions.

## Conclusion

This research aims to design and test an early detection of drought in plants based on soil moisture sensor integrated with Arduino microcontroller. The results of the research show that the developed system is able to effectively provide visual notifications about soil moisture conditions in potted plants, so that users can do watering on time.

The use of the FC-28 sensor is proven to accurately detect changes in soil moisture. This sensor produces an analog signal which is then processed by Arduino to determine whether the soil condition is below the predetermined moisture threshold. If the soil is detected to be dry, the Arduino will activate the LED as a warning indicator. Thus, this tool can provide an effective solution for plant owners who are busy or often forget to water.

The integration of an Arduino microcontroller in this system provides greater flexibility than the simple version without a microcontroller. The Arduino is not only capable of controlling the LED indicators, but also allows further development, such as integration with the Internet of Things (IoT), automatic watering systems, as well as sending notifications to mobile devices. Test results on different types of growing media (loose soil, clay, and husk mixture) proved that the system works consistently and is responsive to changes in humidity. Therefore, it can be concluded that this system is feasible to use as a plant monitoring tool and has great potential to be applied on a household and small farm scale.

## References

- [1] Arpan., Yusup, M., & Ahmad, A. (2024). Implementation of a Smart School Learning system with Internet of Things Technology at SMA Negeri II Binjai. *Instal: Jurnal Komputer*, 16(01), 1-9.
- [2] Orlando, E., & Chandra, Y. I. (2022). Penerapan metode prototype dalam membuat alat penyiraman tanaman otomatis berbasis Mikrokontroler Arduino Uno. *Jurnal Ilmiah Teknik Informatika (TEKINFO)*, 23(2), 9-23.
- [3] Asnidar, A., Paletari, N. H., Hidayanti, W., & Bulaka, B. (2023, November). Rancang Bangun Alat Ukur Kelembaban Tanah Sayur Pertanian Berbasis Mikrokontroler Arduino di Desa Kowioha Kecamatan Wundulako kabupaten Kolaka. In *Prosiding Seminar Nasional Pemanfaatan Sains dan Teknologi Informasi (Vol. 1, No. 1, pp. 559-566)*.
- [4] Marcos, H., & Muzaki, H. (2022). Monitoring Suhu Udara Dan Kelembaban Tanah Pada Budidaya Tanaman Pepaya. *Jurnal Teknologi dan Sistem Tertanam*, 3(2), 32-43.
- [5] Sinaga, A. A., & Aswardi, A. (2020). Rancangan Alat Penyiram Dan Pemupukan Tanaman Otomatis Menggunakan Rtc Dan Soil Moisture Sensor Berbasis Arduino. *JTEIN: Jurnal Teknik Elektro Indonesia*, 1(2), 150-157.
- [6] Yusup, M. (2022). Teknologi Radio Frequency Identification (RFID) sebagai tools system pembuka pintu otomatis pada smart house. *Jurnal Media Infotama*, 18(2), 367-373.
- [7] Yusup, M., Arpan & Ahmad, A. (2025). Desain Logo sebagai Brand Image pada Digital Marketing Produk UMKM dengan Metode (HCD) Human Centered Design di Desa Pematang Serai. *Jurnal Nasional Teknologi Komputer*, 5(2), 07-14.
- [8] Sari, M. D., Fauzi, R., & Lestari, A. P. (2021). Desain Sensor Kelembaban Tanah Menggunakan Modul FC-28 Berbasis Arduino Uno. *Jurnal Teknik Elektro dan Komputer*, 10(1), 34-41.
- [9] Prasetyo, B., & Hidayat, M. (2020). Implementasi Sensor FC-28 dalam Sistem Monitoring Tanaman Otomatis Berbasis Arduino. *Jurnal Teknologi dan Rekayasa*, 8(2), 77-84.

- [10] Kusuma, A. D., Wicaksono, R., & Maulana, H. (2021). Konsep Smart Agriculture Berbasis Mikrokontroler pada Sistem Irigasi Tanaman. *Prosiding Seminar Nasional Teknologi dan Informatika (SENTIKA)*, 2021, 112–118.
- [11] Wahyuni, R., & Hidayat, M. (2022). Penerapan IoT dalam Sistem Monitoring Tanaman Otomatis. *Jurnal Teknologi Informasi dan Terapan*, 14(1), 21–29.
- [12] Herva, D., Anggraeni, Y., & Sitorus, P. (2025). Desain Mini Soil Moisture Sensor Untuk Deteksi Kekeringan Tanaman Pot. *JATISI*, 12(2), 319–331.