

# Comparative Analysis of Polycrystalline and Monocrystalline Solar Panels in PV Systems

Yessica Ariesta Manalu

[yessica.ariesta2017@gmail.com](mailto:yessica.ariesta2017@gmail.com)

Siti Anisah

[sitianisah@dosen.pancabudi.ac.id](mailto:sitianisah@dosen.pancabudi.ac.id)

Universitas Pembangunan Panca Budi, Indonesia

## Abstract

In the solar panel system there are differences in efficiency and characteristics in energy conversion based on light intensity. To determine the differences in efficiency and characteristics, energy production measurements were carried out on monocrystalline solar panels with polycrystalline solar panels. This study discusses the comparison of the two types of solar panels. Measurements were made by giving a lamp load and measuring the energy production of 50W monocrystalline solar panels and 50W polycrystalline solar panels simultaneously from 09.00 WIB to 15.00 WIB. The aim is to obtain data on time, sun angle, light intensity converted into irradiation, voltage, current, and energy conversion production power against the influence of changes in light intensity. From the results of this study, it was found that on polycrystalline solar panels when the highest light intensity value of 119260 lux was recorded at 12.00 WIB with an irradiation value of 989.86 w/m<sup>2</sup>, it produced the highest output value, namely a voltage of 17.35 V and a current of 1.63 A. Meanwhile, on monocrystalline solar panels, when at 12.00 WIB the highest light intensity value was recorded at 119269 lux with an irradiation value of 989.93 w/m<sup>2</sup>, it produced the highest output value, namely a voltage of 15.3 V and a current of 1.51 A. The results of the efficiency calculation based on the data obtained are that monocrystalline solar panels have greater efficiency compared to polycrystalline, monocrystalline solar panels produce an efficiency of 7.2% while polycrystalline solar panels produce an efficiency of 6.9%.]

**Keywords:** Comparison of Polycrystalline and Monocrystalline Solar Panels

**Introduction**

Solar energy cannot be directly utilized to meet electricity needs, but a technology is needed. In Indonesia, there is already a technology that can convert solar energy into electrical energy called photovoltaic or commonly known as solar cells or solar panels. Basically, the utilization of solar energy into electrical energy is to change or convert solar energy absorbed by solar panels into electrical energy. However, the output power produced by solar cells depends on the intensity of sunlight, meaning that the greater the intensity of sunlight captured by solar panels, the greater the electrical power produced.

In the use of solar panels, there are several types of solar panels that are commonly used in Indonesia, namely monocrystalline solar panels and polycrystalline solar panels. The output power produced is also not always the same at all times because there are several aspects that affect it, namely the intensity of sunlight, the type of solar panel used, wind, and the working temperature of the solar panel. Monocrystalline solar panels tend to have a higher price on the market compared to polycrystalline solar panels, because in terms of construction, monocrystalline solar panels use single crystals consisting of single solar cells. This structure produces higher efficiency. Compared to polycrystalline solar panels which are made of several crystals formed together in one module. This makes it cheaper, but also slightly less efficient than monocrystalline.

Therefore, to find out how the comparison of energy conversion efficiency from solar energy to electrical energy between monocrystalline solar panels and polycrystalline solar panels with various intensities of sunlight exposure can produce output power, voltage and current values. So in this study I will discuss the comparative analysis of energy conversion efficiency between monocrystalline and polycrystalline solar panels in various light intensities. It is expected that in several tests, maximum results will be obtained and can be an effective and efficient alternative energy source.

**Literature Review**

Solar panels have an important role in solar power plant installations, solar panels are made of semiconductor materials. To determine the number of solar panels needed, it can be written with the following equation:

$$n_{Panel} = \frac{P_{WP}}{P_{mpp}} \dots\dots\dots(1)$$

Where:

Pwp = Output power (Watt Peak)

Pmpp = Maximum power (Watt Peak)

To calculate the input power of solar panels, you can use the following equation:

$$Pin = Irad \times A \dots\dots\dots(2)$$

Where:

Pin = Input power (W)

Irad = Solar irradiation (W/m2)

A = Cross-sectional area (m2)

To determine the output power of a solar panel, you can use the following equation:

$$P_{out} = V_{pv} \times I_{pv} \dots\dots\dots(3)$$

Where:

$P_{out}$  = Power output from the solar panel (W)

$V_{pv}$  = Solar panel voltage (V)

$I_{pv}$  = solar panel output current (A)

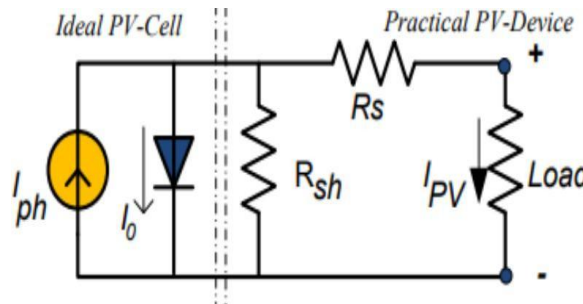

**Figure 1.** PV Equivalent Circuit

A solar cell can be represented as a current source in parallel with a diode. Basically, each solar cell functions as a pn diode. When sunlight reaches the solar cell, the energy received is directly converted into electrical energy without any mechanical components. The emitted light is absorbed in the semiconductor material, utilizing this light energy to produce electron excitation from a low energy level to a higher unoccupied energy level. Therefore, when the solar cell is illuminated, excess electron-hole pairs are generated throughout the cell, causing electrical connections to form at the pn junction and current to flow.  $I_{ph}$  represents the photocurrent of the cell, while  $R_{sh}$  and  $R_s$  are the intrinsic shunt resistance and series resistance of the PV module, respectively.  $I_{ph}$  of a PV module depends linearly on the intensity of sunlight and is also affected by temperature, and can be written as the following equation:

$$I_{ph} = [ I_{SCr} + K_i (T_k - T_{ref}) ] \dots\dots\dots(4)$$

Where:

$I_{ph}$  = current (A)

$K_i$  = coefficient

$T_k$  = actual temperature (K)

$\lambda$  = irradiation (w/m<sup>2</sup>)

$I_{SCr}$  = module short circuit current

The voltage and current generated by the series-connected solar panels are 35.77 V and 3.18 A, respectively. Meanwhile, the voltage and current generated by the parallel-connected solar panels are 17.69 V and 6.38 A, respectively. The power generated by the series circuit is 113.75 Watts, and the power generated by the parallel circuit is 112.86 Watts. The resistance in the series circuit is 11.25  $\Omega$ , while in the parallel circuit it is 2.77  $\Omega$ . Given its advantages and efficiency, for off-grid solar energy system installations, it is better to connect the panels

in parallel. This configuration allows for easier inspection and maintenance in case of damage, as the damaged component can be easily identified while the other panels remain functioning properly, ensuring continuous power flow.

**Research Methodology.**

The method used in this study is the true experimental research method where the data obtained in this study is data that is measured directly outdoors or carried out in an open place to collect data directly in the field. Before conducting the research, the researcher first conducted observation and literature study activities. Where the observation carried out was to survey the location that would be used as a research site and record the equipment and material needs that would be used. While the literature study carried out was to collect several references from articles, scientific publications, and books from various sources related to the research. Through this literature study, we can identify parameters that can be used as a reference in the research process

**Output Testing On Solar Panels.**

This study requires two solar panels, namely a 50 WP monocrystalline solar panel and a 50 WP polycrystalline solar panel. The load used is a lamp with a voltage of 12 V and a power of 25 W. In this test, both panels are positioned at varying angles according to the direction of the sun with an angle range (0 ° -180 °). This test produces voltage and current values on the voltamperemeter and multimeter, between the two, the results are almost the same or close to those shown in the Figure below:

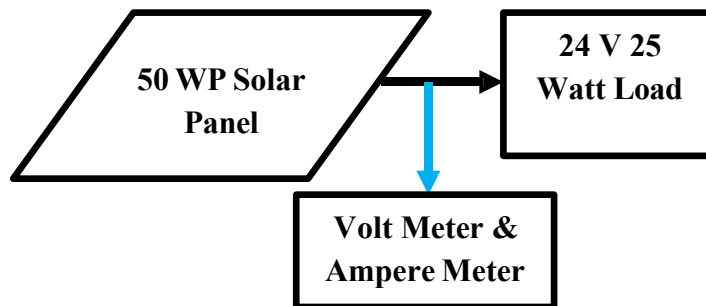

**Figure 2.** Calibration Testing

After the voltage and current measurements on the ammeter and voltmeter have the same value as the multimeter measurements, the voltage and current data read on the ammeter and voltmeter can be used. The current and voltage data collection was carried out for 1 day where each day data collection was carried out with a time interval of every 30 minutes starting at 09.00 - 3.00 WIB where each measurement was carried out 4 times with sunny weather. The data measured were the angle, current, voltage, light intensity of each of the two types of solar panels which then calculated and compared the efficiency values of each type of solar panel. The equation used to determine the efficiency of solar panels can be written as the following equations:

$$\eta_{Panel\ Surya} = \frac{P_{Out}}{P_{In}}$$

$$\eta_{Panel\ Surya} = \frac{V_{PV} \times I_{PV}}{I_{Rad} \times A}$$

Where:

- $\eta$  = Efficiency
- $P_{out}$  = Output power (W)
- $V_{pv}$  = Solar panel voltage (V)
- $I_{pv}$  = solar panel output current (A)

- Pin = Input power (W)
- Irad = Solar irradiation (W/m<sup>2</sup>)
- A = Cross-sectional area of solar panel (m<sup>2</sup>)

For irradiation parameters obtained from the conversion results of light intensity measurements. The standard for measuring solar radiation uses watts per square meter (W/m<sup>2</sup>). Solar radiation measurements are limited by their ability to measure low radiation values. Sunlight measurements measure the value of light flux per unit area (luminance) using lumens per meter or lux. An effective conversion factor between W/m<sup>2</sup> and lux will allow the use of light meters to evaluate photovoltaic performance under low solar irradiation conditions. The literature reviewed is the same as containing equivalent luminous efficacy values ranging from 21 to 131 lux per W/m<sup>2</sup>, 120 lux is equal to 1 W/m<sup>2</sup>, so 1 lux in light intensity measurements is equal to 0.0083 W/m<sup>2</sup>. Conversion factors include standard data and equipment calibration strength.

**Research Series.**

In this study, a closed loop circuit is used as a load or load that connects the solar panel to the load via a volt ampere meter. A closed loop circuit or closed circuit is a system in which the signal or current returns to the initial source after going through various elements in the circuit. In other words, a closed circuit is an electrical circuit consisting of a voltage source and a load connected to a conductor, resulting in an electric current as shown in the Figure below:

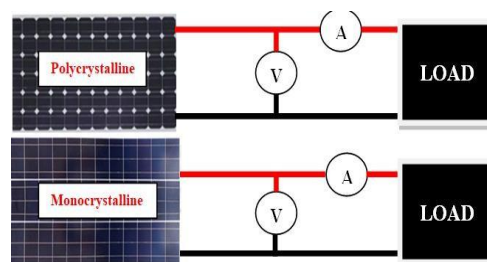

**Figure 3.** Research series

Before conducting output testing on both types of solar panels, a calibration was first carried out between the voltampere meter and the multimeter so that the voltampere to be used produces appropriate data as shown in the table below:

**Table 1.** Calibration data

<i>Monocrystalline</i>				<i>Polycrystalline</i>			
<b>Voltmeter &amp; Ammeter</b>		<b>Multimeter</b>		<b>Voltmeter &amp; Ammeter</b>		<b>Multimeter</b>	
<b>V</b>	<b>I</b>	<b>V</b>	<b>I</b>	<b>V</b>	<b>I</b>	<b>V</b>	<b>I</b>
17.5	1.73	17.40	1.71	17	1.62	16.10	1.7

In the table above, it can be seen that the measurement results on the voltampere meter have been in accordance with or close to the measurement results of the multimeter. Thus, the value produced on the voltampere meter has shown that the measuring instrument is suitable for measurement. Next, below is a flowchart used in the study as shown in the Figure below:

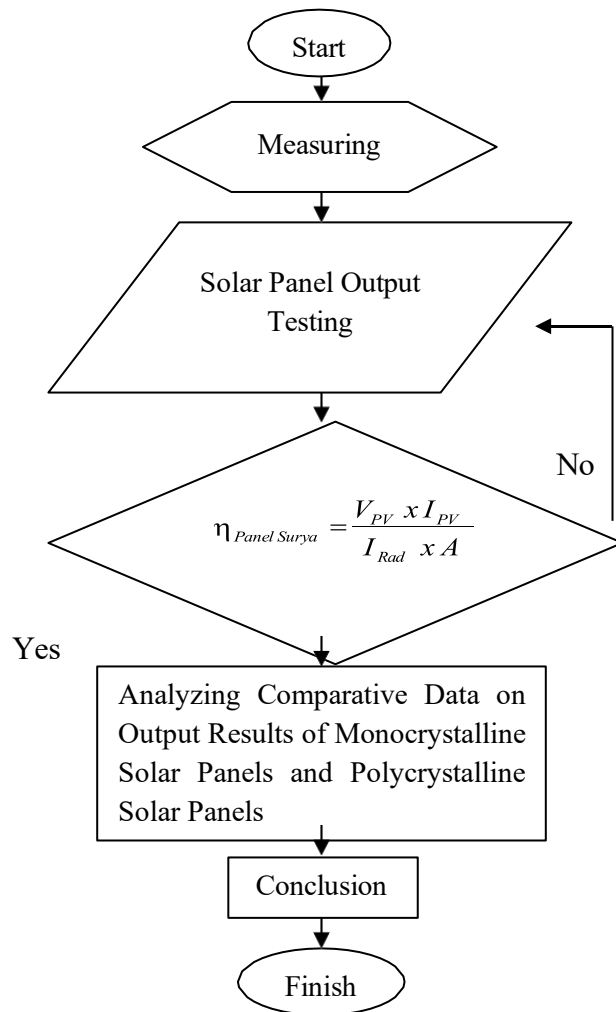

Figure 4. Research Flowchart

**Results.**

In this study, the results of research and analysis that have been carried out will be discussed regarding the comparison of efficiency values between 50 WP monocrystalline solar panels and 50 WP polycrystalline solar panels with various light intensities received.

**Monocrystalline 50 WP Solar Panel Measurement Results.**

In this test, the values of voltage (V), current (I), power (P), light intensity (Lux), and irradiation (W/m<sup>2</sup>) produced on a 50 WP monocrystalline solar panel during the time duration starting from 07.00 WIB to 17.00 WIB, the measurement data can be seen in the following table:

Table 2. Test results of 50 WP monocrystalline solar panels

Time (Wib)	Angle (°)	Voltage (V)	Current (A)	Power (P)	Light Intensity (Lux)	Irradiance (W/m <sup>2</sup> )
09.00	42	16.10	1.58	25.43	84222	699.04
09.30	57	16.12	1.59	25.63	93903	779.39
10.00	61	16.17	1.59	25.71	104641	868.52
10.30	68	16.25	1.6	26	109793	911.28

11.00	73	17.09	1.61	27.51	118505	983.59
11.30	82	17.27	1.61	27.80	118487	983.44
12.00	93	17.35	1.63	28.28	119269	989.93
12.30	95	17.34	1.62	28.09	118064	979.93
13.00	100	17.21	1.61	27.70	114816	952.97
13.30	105	17.18	1.59	27.31	105230	873.41
14.00	120	16.55	1.59	26.31	100366	833.04
14.30	132	16.25	1.57	25.51	87342	724.94
15.00	135	16.17	1.56	25.22	71258	591.44
<b>Average</b>		<b>16.69</b>	<b>1.69</b>	<b>26.65</b>	<b>103530</b>	<b>856.99</b>

Based on the above, it can be explained that at 12.00 WIB the voltage and current produced by the solar panel are the peak voltage or the highest voltage. At that time, the current and voltage produced on the 50 wp monocrystalline photovoltaic reached 1.63 A and 17.34 V. This can be explained clearly that exactly at 12.00 WIB is the time when the sun is at its highest position or peak point, so that the voltage and current values produced are more maximal, while in the measurement at 15.00 it can be seen that the results of the current and voltage measurements began to decrease because the conditions that began to afternoon caused the intensity of the radiation on the solar panel to decrease so that the output value produced by the solar panel also began to decrease. While the power value produced is the result of the multiplication of the current value and the voltage value. In the light intensity test, the light intensity value produced at 15.00 tends to be low because in that condition it is still too early so that the light intensity value produced is less than optimal, this is inversely proportional to when the test is carried out at 12.00 WIB, the light intensity value produced is more optimal compared to the test before and after, because at that time is the time when the sun is at its peak. This also affects the voltage value produced.

### Results of Measurement of 50 WP Polycrystalline Solar Panels

In this test, the values of voltage (V), current (I), power (P), light intensity (Lux), and irradiation (W/m<sup>2</sup>) produced on the Polycrystalline 50 WP solar panel during the time duration starting from 07.00 WIB to 17.00 WIB, the measurement data can be seen in the following table:

**Table 3.** Results of testing 50 Wp polycrystalline solar panels

Time (Wib)	Angle (0)	Voltage (V)	Current (A)	Power (P)	Light Intensity (Lux)	Irradiance (W/m <sup>2</sup> )
09.00	42	13.6	1.47	19.99	84219	699.02
09.30	57	13.9	1.48	20.57	93893	779.31
10.00	61	14.1	1.48	20.87	104632	868.45
10.30	68	14.5	1.49	21.61	109789	911.25
11.00	73	15	1.5	22.50	118498	983.53
11.30	82	15	1.5	22.50	118481	983.39
12.00	93	15.3	1.51	23.10	119260	989.86
12.30	95	14.9	1.5	22.35	118060	979.90
13.00	100	14.7	1.49	21.90	114820	953.01
13.30	105	14.2	1.48	21.02	105237	873.47
14.00	120	14	1.48	20.72	100383	833.18
14.30	132	13.9	1.48	20.57	87336	724.89
15.00	135	13.5	1.48	19.98	71260	591.46
<b>Average</b>		<b>14.35</b>	<b>1.48</b>	<b>12.36</b>	<b>152862</b>	<b>852,286</b>

From the table above, it can be explained that at 12.00 WIB the voltage produced by the solar panel is the peak voltage or the highest voltage. At that time, the current and voltage results produced on the 50 wp polycrystalline photovoltaic are different from the current and voltage results produced on the 50 wp monocrystalline photovoltaic, which reaches 1.51 A and 15.3 V. This can be explained that the monocrystalline type solar panel has a pure silicon base material, which means that the monocrystalline type solar panel has a better conductivity level which allows for a more efficient flow of electricity after solar energy is converted into electrical energy. In addition, single silicon also has a more regular crystal structure, this allows electrons to move more efficiently and increases the ability to absorb solar energy so that it can produce higher power compared to other types of solar panels. while the polycrystalline type solar panel is made from mixed silicon, which means that the results of the conversion of electrical energy from the monocrystalline type solar panel are better than the 50 wp polycrystalline solar panel, this is what causes the monocrystalline type solar panel to produce a higher voltage and current output value compared to the polycrystalline type solar panel.

### Efficiency Calculation Results on 50 WP Monocrystalline Solar Panels

Calculation of the efficiency of a 50 wp monocrystalline solar panel based on the results of the experimental data can be calculated as follows:

VPV	=16.6
IPV	=1.69
Irradiation	=856.99 w/m <sup>2</sup>
Pv cross-sectional area (A)	=0.4509 m <sup>2</sup>

So:

$$\eta_{\text{Panel Surya}} = \frac{V_{PV} \times I_{PV}}{I_{Rad} \times A} \times 100\%$$

$$\eta_{\text{Panel Surya}} = \frac{16,6 \times 1,69}{856.99 \times 0,4509} \times 100\%$$

$$\eta = 7,2\%$$

### Efficiency Calculation Results on 50 WP Polycrystalline Solar Panels

Calculation of the efficiency of a 50 wp Polycrystalline solar panel based on the results of the experimental data carried out can be calculated as follows:

VPV	=14.35
IPV	=1,48
Irradiation	=852.28w/m <sup>2</sup>
Pv cross-sectional area (A)	=0.3604 m <sup>2</sup>

So:

$$\eta_{\text{Panel Surya}} = \frac{V_{PV} \times I_{PV}}{I_{Rad} \times A} \times 100\%$$

$$\eta_{\text{Panel Surya}} = \frac{14,35 \times 1,48}{852.28 \times 0,3604} \times 100\%$$

$$\eta = 6,9\%$$

From the research that has been done, on the monocrystalline 50 wp solar panel with the highest light intensity obtained at 12.00 WIB, which is 119260 lux, producing a voltage output of 17.35V, a current of 1.63 A, and a power of 28.28W. On the polycrystalline 50 wp solar panel, the highest light intensity was obtained at 12.00 WIB, which is 119,260 lux, producing a voltage output of 15.3 V, a current of 1.51 A, and a power of 23.10 W. Then the calculation of efficiency, it can be seen that both types of solar panels that were tested simultaneously in hot weather conditions, the efficiency value of the monocrystalline 50 wp solar panel was

greater, which was 7.2%. While the polycrystalline 50 wp solar panel has a smaller efficiency, which is 6.9%.

This can be explained that in conditions that are often exposed to the sun or hot, it is suitable to use monocrystalline solar panels. In addition, based on the theory above, it is explained that the basic material of monocrystalline solar panels is pure silicon or single silicon which can absorb and convert electrical energy more optimally compared to polycrystalline solar panels which have a mixed silicon base material.

### Conclusion.

From the research results above, the following conclusions can be drawn:

- a. The higher the light intensity or irradiation value received by the solar panel, the greater the output value produced.
- b. Monocrystalline solar panels produce higher output values compared to polycrystalline solar panels.
- c. Based on calculations from research data, the efficiency value of monocrystalline solar panels is 7.2% greater than the efficiency value of polycrystalline solar panels, which is 6.9%.
- d. In hot weather conditions or with more exposure to the sun, monocrystalline solar panels are more efficient, although the difference is not too great.

### References.

- Arif Zulfahri Siregar, Zuraidah Tharo, Dino Erivianto, 2024 "Analysis of Solar Power Generation System Design on Airport Tower Support Facilities" Journal of Information Technology and Computer Science (INTECOMS) Volume 7 Number 6, Year 2024 e-ISSN: 2614-1574 p-ISSN: 2621-3249
- Dicky Ananda Tanjung, Syamsul Bahri Purba, Angga Aditya Saputra, Solly Aryza, Siti Anisah, 2020 "Improving Automatic Sun Tracking and Autofocus for Solar Cell Actuators on PLTS" Seminar of Social Sciences Engineering & Humaniora SCENARIO 2020| Medan -Saturday, December 26, 2020 e-ISSN 2775-404
- Ervan Pratama and Richa Watiasih 2020 "Comparison of Power Gain of Monocrystalline Solar Panels to Polycrystalline Solar Panels" ELKHA, Vol. 12, No.2, October 2020, pp. 105 - 111 ISSN: 1858-1463 (print), 2580-6807 (online)
- Hamdani, ST., MTSiti Anisah, ST,.MTZuraidah Tharo, ST,.MT, 2022 "Implementation of Solar Power Plants (PLTS) for Residential Homes" ISBN: 978-623-5488-48-6
- Hutur Tuan Badogil, Ahmad Dani, Dino Erivianto 2024 "Study of Optimization of Tilt Angle and Azimuth of Solar Panels on PLTS Output Using PVSyst Software" Journal Of Social Science Research Volume 4 Number 6 Year 2024 Page 83-95 E-ISSN 2807-4238 and P-ISSN 2807-4246 Website:<https://j-innovative.org/index.php/Innovative>
- Mietra Anggara, Widi Saputra, 2023 "Performance Analysis of Monocrystalline and Polycrystalline Solar Cells in Sumbawa Regency, NTB" FLYWHEEL JOURNAL, February 2023, Vol 14 (1), 7-12 E-ISSN: 2745-7435 P-ISSN: 1979-5858
- Muhammad Yusuf Maulana, Budi Pramono Jati, and Ida Widiastuti, 2024 "Comparative Analysis of Energy Conversion Efficiency Between Monocrystalline 50 WP and Polycrystalline 50 WP PV (Photovoltaic) at Various Light Intensities" Journal of Electrical Engineering Vol. 7 | No. 02 | Pages 1-7 ( P-ISSN 2614-5146) and (E-ISSN 2614-5499 )
- Mujammil Asdhiyoga Rahmanta, Agussalim Syamsuddin, Fefria Tanbar, Natalina Damanik, 2023 "Analysis of the Development of Photovoltaic (PV) Module Technology to Increase Penetration of Solar Power Plants (PLTS) in Indonesia" Offshore Journal: Oil, Production Facilities and Renewable Energy Volume 7 No. 1 June 2023 : 28 — 39 : ; e -ISSN : 2549-8681
- Nur Atikah1, Budi Pramono Jati2, and Dedi Nugroho, 2024 "Analysis of the Effect of Temperature on Output Power on Monocrystalline and Polycrystalline 50 Wp Solar

Panels” Journal of Electrical Engineering Vol. 7 | No. 02 | Pages 18-25 P-ISSN 2614-5146) and (E-ISSN 2614-5499

Siti Anisah, Amani Darma Tarigan, 2023 “Planning of Atapon Grind Solar Power Plant as an Environmentally Friendly Alternative Energy Source” Journal of Information Technology and Computer Science (INTECOMS) Volume 6 Number 1, June 2023 e-ISSN: 2614-1574 p-ISSN: 2621-3249

Siti Anisah, Rahmadhani Fitri, Hamdani, Albert Kenedy Butar Butar, Zuraidah Thar 2022, "Study Of The Potential Of New Renewable Energy Generation (Hybrid Solar And Wind) As An Alternative Energy Source" Proceedings International Conference of Science Technology and Social Humanities ICESHI 2022.